



SAB-QS Quick Start

This document aims to provide a systematic setup procedure to enable you to setup and use your SAB-QS as easily as possible. This guide will concentrate on connections and basic setup. More information is available for advanced setup, refer to the SAB-QS manual. If you do not have a TDD manual, call Rapid Controls or visit the Rapid Controls website, www.rapidcontrols.com.

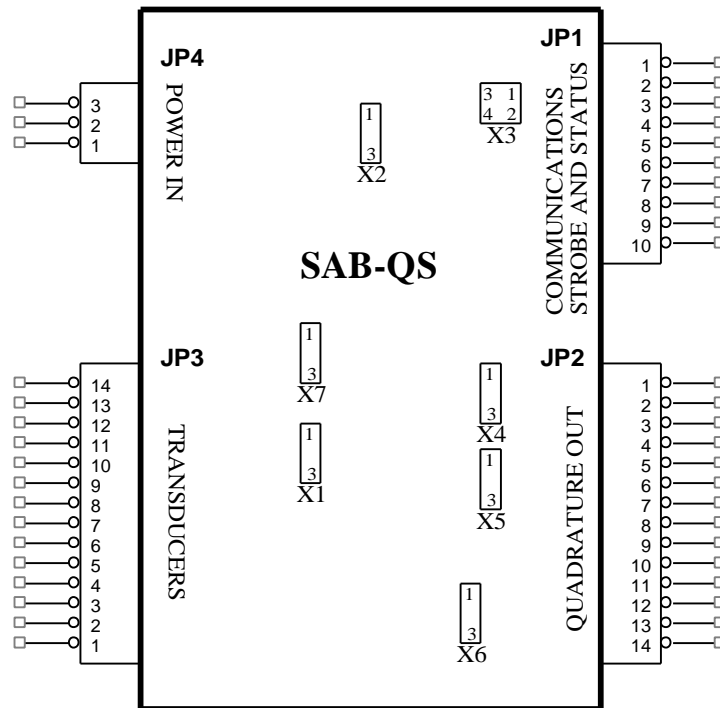

Figure 1: SAB-QS Connector and Jumper Placement

1. Power Connection (Connector JP4)

Power input to JP4 provides power to the board and the transducers. Refer to the transducer requirements before choosing a power source for the SAB-QS. The following pins must be connected:

Pin 1 is connected to either +24VDC or +15VDC depending on the requirements of the transducer.

Pin 2 is connected to ground.

Pin 3 is connected to -15VDC if required by the transducer. Otherwise, no connection is made.

Rapid Controls Inc.

Box 8390 ▪ Rapid City, SD ▪ 57709

Phone: 605-348-7688 ▪ Fax: 605-341-5496

<http://www.rapidcontrols.com/> ▪ email: info@rapidcontrols.com

2. Transducer Connections (Connector JP3)

JP3 provides the connections to the transducers. Power from JP4 is passed through to the transducer on JP4 pins 5, 7, 12, and 14. The following pins must be connected for operation of transducer channel 0:

Pin 1 is connected to the transducer CLK+/INT+ wire (yellow).

Pin 2 is connected to the transducer CLK-/INT- wire (green).

Pin 3 is connected to the transducer DATA+/GATE+ wire (pink).

Pin 4 is connected to the transducer DATA-/GATE- wire (gray).

Pin 5 is connected to the transducer +power wire (red or brown).

Pin 6 is connected to the transducer ground wire (white). The shield may need to be connected, depending on the type of transducer (see included note).

Pin 7 is connected to the transducer –power wire (blue) if needed.

The following pins must be connected for operation of transducer channel 1:

Pin 8 is connected to the transducer CLK+/INT+ wire (yellow).

Pin 9 is connected to the transducer CLK-/INT- wire (green).

Pin 10 is connected to the transducer DATA+/GATE+ wire (pink).

Pin 11 is connected to the transducer DATA-/GATE- wire (gray).

Pin 12 is connected to the transducer +power wire (red or brown).

Pin 13 is connected to the transducer ground wire (white). The shield may need to be connected, depending on the type of transducer (see included note).

Pin 14 is connected to the transducer –power wire (blue) if needed.

Note: Transducer wire colors are MTS Temposonics wire colors. Other manufacturers may use different colors.

3. Quadrature Connections (Connector JP2)

The quadrature output from the SAB-QS is provided on connector JP2. The following connections should be made for operation of quadrature channel 0:

Pin 1 is connected to the quadrature line A input of the controller.

Pin 2 is connected to the quadrature line /A (A not) input of the controller.

Pin 3 is connected to the quadrature line B input of the controller.

Pin 4 is connected to the quadrature line /B (B not) input of the controller.

Pin 7 is connected to logic ground.

Rapid Controls Inc.

Box 8390 ▪ Rapid City, SD ▪ 57709

Phone: 605-348-7688 ▪ Fax: 605-341-5496

<http://www.rapidcontrols.com/> ▪ email: info@rapidcontrols.com

The following connections should be made for operation of quadrature channel 1:

Pin 8 is connected to the quadrature line A input of the controller.

Pin 9 is connected to the quadrature line /A (A not) input of the controller.

Pin 10 is connected to the quadrature line B input of the controller.

Pin 11 is connected to the quadrature line /B (B not) input of the controller.

Pin 14 is connected to logic ground.

4. Serial Communications (Connector JP1 and Jumper X2)

Connector JP1 provides serial communications (in addition to other features, see below). Both RS-232 and RS-485 are available. For more information on using RS-485, see the SAB-QS manual. Jumper X2 must be set 2-3 for RS-232. The following pins must be connected for RS-232 communications:

Pin 1 is connected to logic ground on the host computer (pin 5 on a DB-9 connector, pin 7 on a DB-25 connector).

Pin 2 is the SAB-QS's receive line and is connected to the host computer's transmit line. (pin 3 on a DB-9 connector, pin 2 on a DB-25 connector)

Pin 3 is the SAB-QS's transmit line connected to the host computer's receive line. (pin 2 on a DB-9 connector, pin 3 on a DB-25 connector)

If the host computer requires the use of hardware handshaking, the host's DTR line must be tied to the host's DSR line (pin 4 to pin 6 on a DB-9), and the host's RTS line must be tied to the host's CTS line (pin 7 to pin 8 on a DB-9).

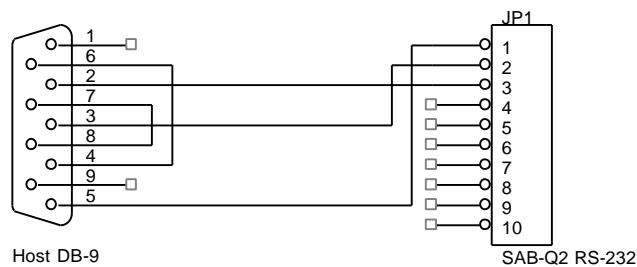

Figure 2: Diagram of SAB-QS RS-232 Serial Cable

Note: Wires between pins 4 and 6 and pins 7 and 8 can be omitted if host computer does not require hardware handshaking.

After connecting the host computer to the SAB-Q2 and setting the correct communications parameters, apply power to the SAB-Q2. Press the spacebar several times quickly. The SAB-Q2 will respond with a menu. If the SAB-Q2 does not present a menu, check the serial cabling and software setup, make sure jumper X2 is set correctly: 1-2 for RS485 or 2-3 for RS232.

Rapid Controls Inc.

Box 8390 ■ Rapid City, SD ■ 57709

Phone: 605-348-7688 ■ Fax: 605-341-5496

<http://www.rapidcontrols.com/> ■ email: info@rapidcontrols.com

5. Dip Switch S1

Dip-switch S1 controls the speed of quadrature output and can be used to select setup parameters instead of using menu-based setup. For 750 KHz output, set all switches off; for 375 KHz output, set switches 1 and 5 on and all other switches off. For more information regarding dip-switch setup, see the SAB-QS manual.

6. Strobe Inputs and Transducer Status Outputs (Connector JP1)

Connector JP1 is also used for strobe inputs and transducer status outputs. The two strobe inputs command the SAB-QS to send the current position of the transducer over the quadrature channel. A pulse less than 100 us will cause a relative position update. A pulse greater than 100 ms will cause an absolute position output. More information on timing for the strobe inputs is available in the SAB-QS manual.

The transducer status relay outputs show the status of the transducers. The relay contacts will be closed when the transducer is operating properly.

The strobe inputs can be configured to be low or high-active by changing jumpers X4 and X5. For low-active inputs install X4 and X5 1-2. For high-active inputs install X4 and X5 2-3.

The followings pins are used for the send all inputs and transducer status outputs:

Pin 6 is the strobe input for channel 0. Activating this input for less than 100 us will cause the SAB-QS to send a position update for channel 0. Activating this input for more than 100 ms will cause the SAB-QS to send the absolute position for channel 0.

Pin 7 is the strobe input for channel 1. Activating this input for less than 100 us will cause the SAB-QS to send a position update for channel 1. Activating this input for more than 100 ms will cause the SAB-QS to send the absolute position for channel 1.

Pin 8 is the I/O common.

Pin 9 is the channel 0 transducer status contact. A closed contact indicates a good transducer.

Pin 10 is the channel 1 transducer status contact. A closed contact indicates a good transducer.

7. Initial Power Up

After all connections are complete and have been checked for errors, apply power to the SAB-QS. The red board status LED should blink. A green transducer status LED should light for each connected transducer with a magnet.

If the board status LED does not blink when power is applied, check that your power connections are correct (see section 1).

If your transducer is a PWM transducer, you must perform some setup before determining correct transducer operation. Please perform the setup described in sections 7 and 8a before continuing with this section.

If the transducer status LED(s) do not light, appear dim or flicker, check that the transducer magnet is installed as prescribed in your transducer documentation. If the LED(s) still do not light, remove power from the SAB-QS and verify all transducer connections.

If, after insuring the transducer connections are correct, the SAB-QS still does not light the transducer status LED(s), verify that your SAB-QS model is capable of supporting your transducer. The SAB-QS-

Rapid Controls Inc.

Box 8390 ▪ Rapid City, SD ▪ 57709

Phone: 605-348-7688 ▪ Fax: 605-341-5496

<http://www.rapidcontrols.com/> ▪ email: info@rapidcontrols.com

?-RPM models are capable of operating with Start/Stop and PWM transducers. The SAB-QS-?-SSI models are capable of operating with SSI transducers.

8. Transducer Setup

A. Transducer Type

If you are using a PWM transducer, you must change the transducer type to PWM. If you are using a SSI or Start/Stop transducer, choose RPM as the transducer type.

B. Recirculations

The number of recirculations determines the worth of each count. A higher number of recirculations increases the resolution of the counts but increases the update time. The approximate value of a count can be determined through the following formula: $(0.002 \div \text{recirculations})$ inches per count. Recirculations only need to be set when using a Start/Stop transducer; otherwise, set the recirculations to 1.

9. Further Setup

Some material related to setup of the SAB-QS is not covered in this guide. For more information on advanced setup, see the SAB-QS manual.

Rapid Controls Inc.

Box 8390 ■ Rapid City, SD ■ 57709

Phone: 605-348-7688 ■ Fax: 605-341-5496

<http://www.rapidcontrols.com/> ■ email: info@rapidcontrols.com